

# The Space Framework

Giovanni Nicola D'Aloisio\*  
University of Pavia, Via Adolfo Ferrata, 5, 27100, Pavia (Italy).

**This is the concept of an interplanetary Space Framework, aimed to introduce the resources of the Solar System into the current terrestrial economy, speeding up the economic transition in space and improving the safety and flexibility of space flight for space exploration.**

**To achieve these ambitious goals, it is necessary to focus on the development of new generation space stations, capable for advanced technological research and tourism and incorporating shipyard-like facilities, a new vehicle for atmospheric and extra-atmospheric transport of people and cargo, and new facilities on the main celestial bodies of the Solar System, for in-situ utilization of resources and working of the same directly in space.**

**Together with these technological developments, a parallel economic and political work is also needed. Following the release of the Outer Space Treaty in 1967, the actual laws and procedures in space are too weak for granting peace in the context that the framework is aiming to build. Following the development of these laws, the international partner will cooperate to make the program safe and sustainable for further development.**

## Contents

<b>I</b>	<b>Why building a space plan?</b>	<b>1</b>
I.A	Jupiter and Shoemaker-Levy 9 and the need of space safety . . . . .	2
I.B	An interplanetary industry beyond planetary defense . . . . .	2
I.C	The legacy and challenges of Space Exploration . . . . .	4
I.D	Assessing the limitations of the Outer Space Treaty . . . . .	5
<b>II</b>	<b>Transport systems and overall architecture</b>	<b>8</b>
II.A	Project Ikarus and the Spectre multipurpose spacecraft . . . . .	8
II.B	Project Laserfan and the Skyraker propulsion system . . . . .	10
II.C	Project Kyber and the X-RAYJAR energy system . . . . .	11
II.D	Project Konigsberg and the Redstar space stations . . . . .	12
<b>III</b>	<b>Perspectives on human evolution enabled by the Space Framework</b>	<b>14</b>
<b>IV</b>	<b>Supportability, maintainability and public participation</b>	<b>14</b>
<b>V</b>	<b>Aftermath</b>	<b>15</b>

## I. Why building a space plan?

In recent years, the weight of space activities on the world economy is increasingly large and is expected to grow further in the years to come. The latest industrial revolution has highlighted the importance of preserving the world and its ecosystems for generations to come, by starting circular economies. New branches of science have seen the light and at the same time new market dynamics have established themselves, first with the digitization of banking transactions and then the advent of cryptocurrencies, but humanity is definitely destined to maintain its activities with more advanced technologies, greater energies and more efficient, effective and clean materials.

---

\*E-mail: giovanninicola.daloisio01@universitadipavia.it - Website: <https://nikitodos.github.io/> - Twitter: @nikitodoss



**Fig. 1 Shoemaker-Levy 9 and Jupiter, before and after the impact.**

#### **A. Jupiter and Shoemaker-Levy 9 and the need of space safety**

At the beginning of the 90s one of the most spectacular collisions ever documented occurred: that between Jupiter and comet Shoemaker-Levy 9. Discovered on March 25, 1993, it had been captured between the second half of the sixties and the early seventy from Jupiter, and the tidal forces had caused it to break up into 21 fragments.

An extensive observational campaign was started involving numerous observers on Earth and probes in space to record the event. Between 16 and 22 July 1994, the fragments of the comet (already destroyed, having passed the Roche limit for Jupiter) fell in a veritable bombardment. The dark spots that formed on the planet were observable from Earth for several months before being reabsorbed by giant's atmosphere. The event had considerable media coverage, but also contributed significantly to scientific knowledge of the Solar System, having enabled to make measurements on the deep layers of the Jovian atmosphere, and underlined the role of Jupiter in reducing the space debris in the inner Solar System.

Spectroscopic observations showed that ammonia  $\text{NH}_3$  and carbon disulphide  $\text{CS}_2$  remained in the atmosphere for at least fourteen months after the event. In the major impact points, temperatures increased in a region ranging from 15,000 to 20,000 km, but dropped to normal values within a week of the event. At smaller spots, temperatures 10 K higher than at surrounding sites persisted for at least two weeks. Stratospheric temperatures rose immediately after the impacts, falling two to three weeks later to lower temperatures than before the impacts.

#### **B. An interplanetary industry beyond planetary defense**

There are similar objects in circumterrestrial space: they are called NEOs, Near-Earth Objects, and they are as interesting as they are dangerous for the Earth. Very similar to these objects, the largest fragments of Shoemaker-Levy 9 destroyed only at a pressure of 2.5 bar, and the marks left by the event remained visible for a long time and were described as more visible than the famous Great Red Spot. It is therefore quite evident that the consequences of an event like this would have been much more drastic on a planet like Earth. However, NEOs are not just threats: from these objects, valuable injectable resources in the global economy can be undermined.

Metal-rich near-Earth asteroids represent a small fraction of the NEA population that is mostly dominated by S- and C-type asteroids. From the near-infrared spectroscopic data of NEAs 6178 (1986 DA) and 2016 ED85, it was determined that these objects were likely transported to the near-Earth space via the 5:2 mean motion resonance with Jupiter. Asteroid spectra were compared with the spectra of mesosiderites and bencubbinites. In particular, mesosiderites were found to have a similar pyroxene chemistry and produced a good spectral match when metal was added to the silicate component. Also, it was estimated that the amounts of Fe, Ni, Co, and the platinum group metals present in 1986 DA could exceed the reserves worldwide.

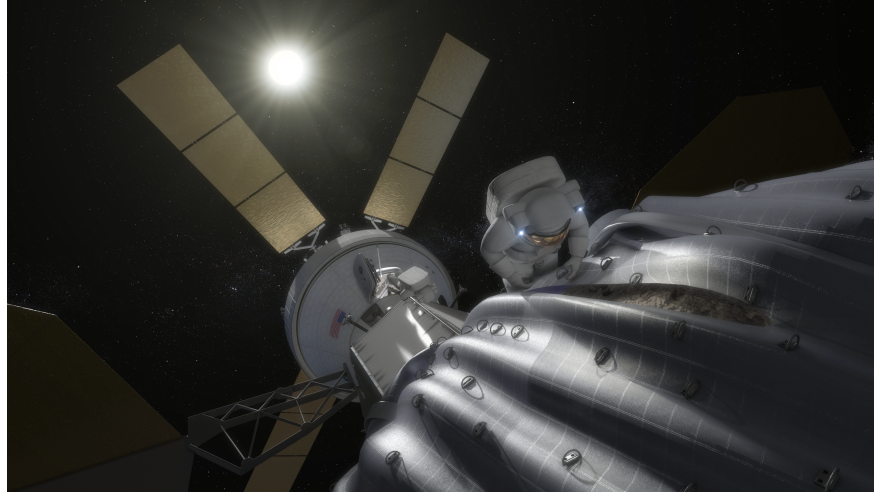
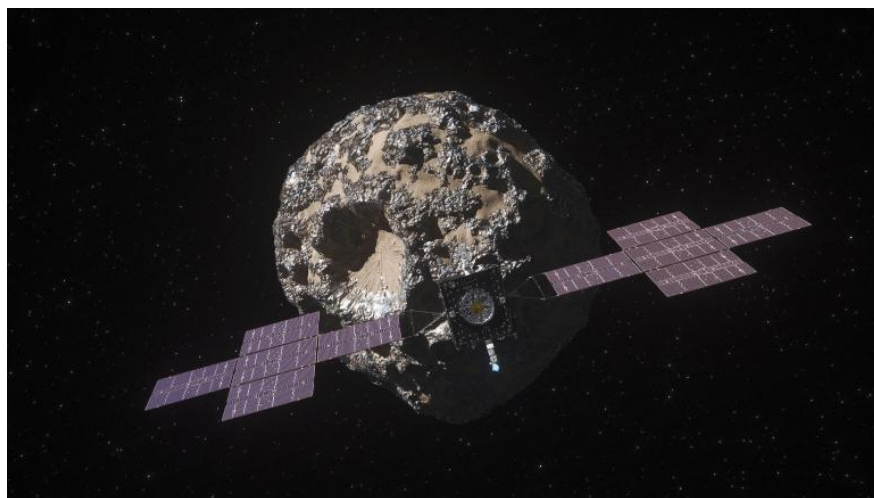

**Fig. 2 An ARRM option was to deploy a container large enough to capture a free-flying asteroid.**

In light of all this, the idea is very simple: from the spectroscopic analysis the composition of the object is detected, and on the basis of these it is decided whether to make it explode using a conventional H-bomb implanted with a suitable spacecraft, or to redirect it to a pre-existing network of asteroids responsible for mining exploitation.

After the first flybys of the Galileo and Cassini spacecrafts, no probe has been interested in asteroids; this until the launch of Deep Space 1 and Dawn. The success of Deep Space 1, the first interplanetary spacecraft to use an electrostatic grid drive, laid the foundations for future spaceflights equipped with ion propulsion, in particular for Dawn, which successfully achieved all of its objectives, totaling over 51 thousand hours of ignition time of the NSTAR thruster. The basic concept is very simple: high voltage electrodes accelerate an ionized gas by electrostatic forces, producing thrust.

Nowadays, the studies underway within the Asteroid Redirect Robotic Mission (ARRM) are fundamental, and after the launch of the first probe directly aimed at planetary defense (the Double Asteroid Redirection Test, DART), it is also expected to have the first probe that will study a metallic asteroid, 16 Psyche, in October 2023. Note how all these missions use ion thrusters. Since NASA's DART spacecraft intentionally slammed into the asteroid moonlet Dimorphos on 26th September 2022 – altering its orbit by 33 minutes – the investigation team has been digging into the implications of how this planetary defense technique could be used in the future, if such a need should ever arise. It has been observed that DART's impact displaced over one million kg of dusty rock into space – enough to fill six or seven rail cars.



**Fig. 3 The Psyche mission will orbit a metal-rich asteroid in the main asteroid belt to investigate its composition.**

There is also the possibility of exploiting the rotational kinetic energy of a small asteroid with a magnetosphere strong enough to generate electricity in a similar way to what occurs in conventional synchronous alternators. Once the kinetic energy of a single asteroid is exhausted, the single generation system can be disassembled to exploit another one; the energy generated can be sent via electromagnetic waves where it is required, used in situ or stored in batteries. Furthermore, robotic systems can autonomously send, as done by numerous past missions the useful mineral resources located in these small celestial bodies, under the supervision of remote humans or, possibly, in the place itself.

### C. The legacy and challenges of Space Exploration

When one reads documents connected with the 1969-1971 Integrated Program Plan (IPP), it is often difficult to decide whether to laugh or to cry. The IPP, a product of George Mueller's Office of Manned Space Flight, began to evolve as early as 1965, but did not take on the grandiose form NASA Administrator Thomas Paine stubbornly advocated to President Richard Nixon until May 1969. Paine, a Washington neophyte, expected that the IPP would be NASA's reward for winning the race to the moon. He believed that, having vanquished the Soviets, it was time for the U.S. civilian space agency to "think big." Nixon's Office of Management and Budget had made it clear that NASA should expect rapidly declining annual budgets, not rapidly growing ones. Nixon interpreted Paine's stubborn advocacy of the ambitious IPP as a clumsy effort at bureaucratic empire building, not as a real proposal for a bold space program.

This was the first step to the aerospace industry, since the beginning of this era in late Fifties. It was the disaster of Space Shuttle Columbia, however, combined with a series of unfortunate events occurred in the late Nineties, to have drastically reduced the possibility of continuing on the same line of the Sixties for scientific research in space.

Here are just a few of the main research areas that are experiencing the greatest slowdowns in this historical period:

- Engineering of In-Situ Research Utilization techniques, for the establishment of colonies on other celestial bodies;
  - Consolidation of knowledge on cryogenics and space awakening for long-duration flights;
  - Deepening of the effects of the long permanence of space on the physical and psyche of living beings;
  - Directly search for evidence of extraterrestrial life, in the Solar System and on the closest stars;
  - Astrophysics, particle physics and matter physics experiments in space;
  - Testing of terrestrial technologies in space and certification of industrial products;
  - Study of the effects of solar wind and cosmic rays on materials and life forms at different levels of shielding.
- One of these points can be seen in further detail in the following page.

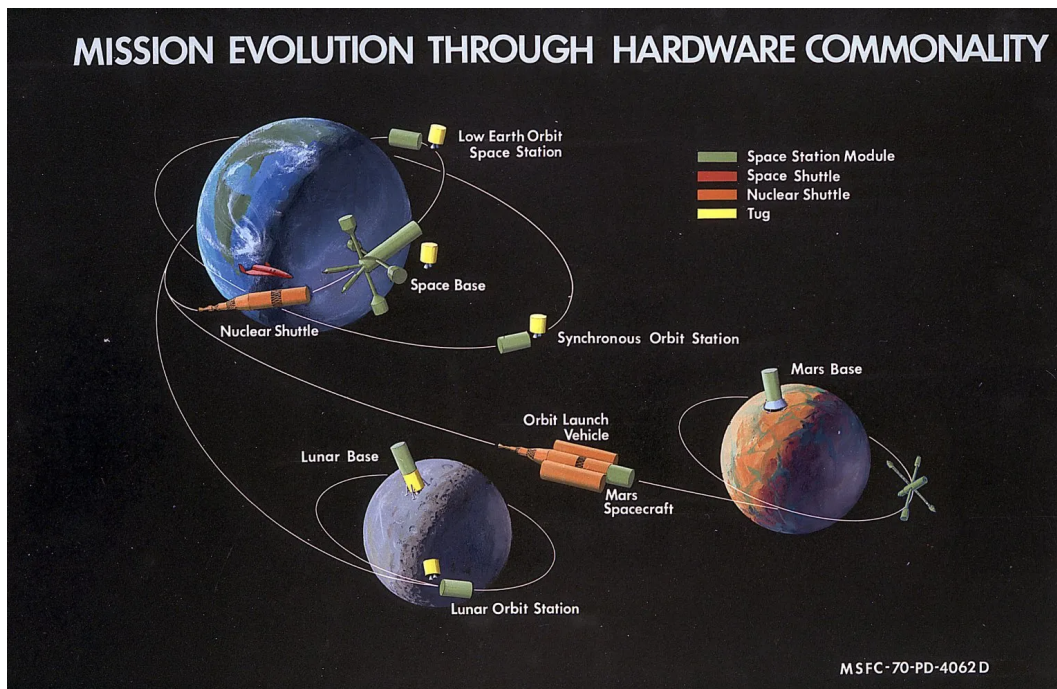
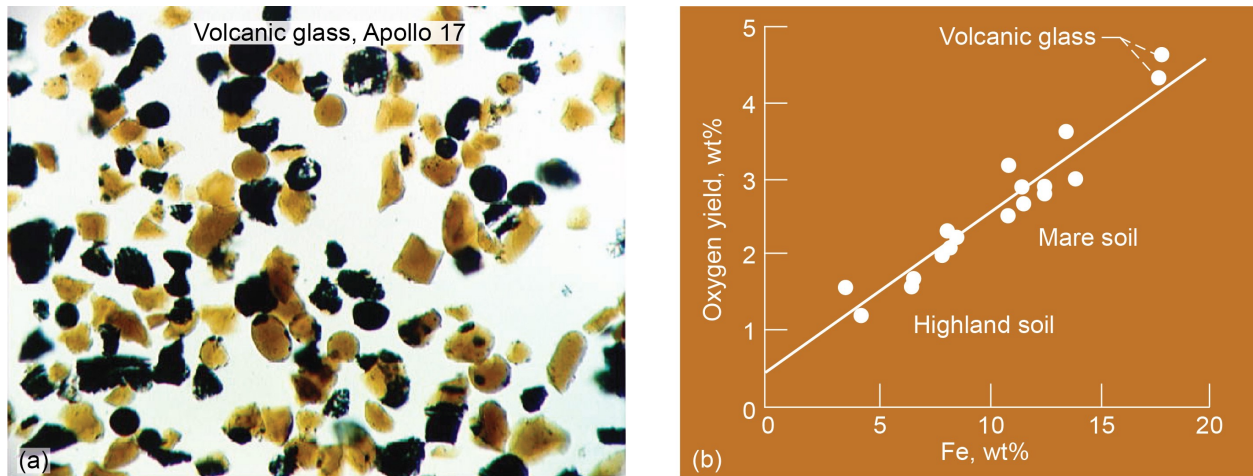

Fig. 4 Integrated Program Plan "Maximum Rate" Traffic Model (1970).





**Fig. 5 Volcanic glass beads and oxygen yields from full range of Apollo samples.**

Lunar-derived propellants (LDPs) will be essential to reducing the launch mass requirements from Earth and developing a reusable lunar transportation system (LTS) that can allow initial outposts to evolve into settlements supporting a variety of commercial activities like in-situ propellant production. Deposits of icy regolith found within permanently shadowed craters at the lunar poles can supply the feedstock material to produce liquid oxygen (LO<sub>2</sub>) and hydrogen (LH<sub>2</sub>) propellant needed by surface-based lunar landing vehicles (LLVs) using chemical rocket engines. Along the Moon’s nearside equatorial corridor, iron oxide-rich volcanic glass beads from vast pyroclastic deposits, together with mare regolith, can provide the materials to produce lunar-derived LO<sub>2</sub> plus other important solar wind implanted (SWI) volatiles, including H<sub>2</sub> and helium-3. Megawatt-class fission power systems will be essential for providing continuous “24/7” power to processing plants, evolving human settlements, and other commercial activities that develop on the Moon and in orbit. Reusable LLVs will provide cargo and passenger “orbit-to-surface” access and will also be used to transport LDP to Space Transportation Nodes (STNs) located in lunar polar (LPO) and equatorial orbits (LLO). Spaced-based, reusable lunar transfer vehicles (LTVs), operating between STNs in low Earth orbit (LEO), LLO, and LPO, and able to refuel with LDPs, can offer unique mission capabilities including short transit time crewed cargo transports. Even a commuter shuttle service appears possible, allowing 1-way trip times to and from the Moon as short as 24 hours. If only 1% of the LDP obtained from icy regolith, volcanic glass, and SWI volatile deposits were available for use in lunar orbit, such a supply could support routine commuter flights to the Moon for thousands of years!

#### **D. Assessing the limitations of the Outer Space Treaty**

The primary source for international law in space is a drastically outdated document from 1967 called the Outer Space Treaty, designed for an environment far simpler than the current field. That document was signed by the United States, the USSR, and sixty other nations on the evening of January 27, 1967, and it basically bans placing nuclear weapons and weapons of mass destruction into orbit. It says nothing of Earth-to-space or space-to-space arms, nor does it speak to kinetic weapons or the many subtler forms of attack developed since its drafting, and though it states that international law extends into space, there is no ready translation of earthly rules to a realm without national borders or gravity. As the years have gone by, the insufficiency of the Outer Space Treaty has become a significant danger.

The vast majority of satellites are split between the more accessible low Earth orbit (LEO), which begins about 500 km from the planet’s surface (ideal for telecommunications and imaging), and geosynchronous orbit (GEO), 36,000 km away, where satellites are stationary on given points (ideal for meteorology). Civilian dependence on satellites - for internet service, cell signals, weather monitoring, geolocation - is higher than ever, and American and European military reliance on satellites is near total. The military’s space-based systems underpin everything: communications, surveillance, guided munitions, nuclear command and control.

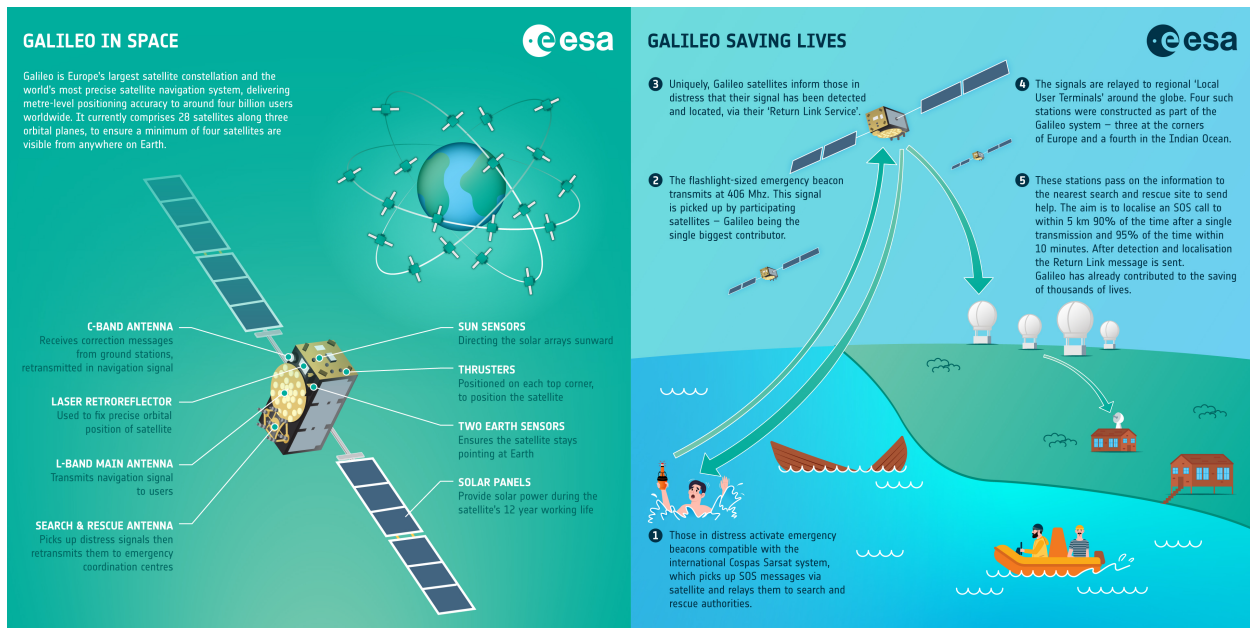

**Fig. 6 Galileo is Europe’s largest satellite constellation and the world’s most precise satellite navigation system, delivering metre-level positioning accuracy to around four billion users worldwide. It currently comprises 28 satellites along three orbital planes, to ensure a minimum of four satellites are visible from anywhere on Earth.**

Direct kinetic attacks on space assets, and the resultant debris, could create a cascading effect that would wreck the satellites we depend on. In the case of widespread destruction, hurricane tracking, search-and-rescue locators, financial transactions, and emergency messages could all go dark. The most important satellites, such as those communicating directives to the military, are hardened against attack, with protective shields and special maneuvering capabilities, and are backed up by others. So it would take dozens of successful shots to bring down a whole satellite constellation.

The new military doctrine embraced by U. S. Space Force inaugurates space as a distinct war-fighting domain, and “spacepower” as a military power in its own right. Among the Space Force’s goals, it says, are to “destroy, nullify, or reduce” adversarial menaces in space, especially by deterrence through the flexing of enormous military muscle. The document is reverential of the international law, but at its core, the doctrine opposes the fundamental purpose of the OST, which was to define and preserve space as a place of peace. It explicitly says: “No domain in history in which humans contest policy goals has ever been free from the potential for war”. The United States’ position is that the extraction and use of resources on the moon and other celestial bodies does not violate that nonappropriation principle. But the United States’ position is also for those resources to not be treated as the property of the whole international community.

All challenges to nuclear weapons remain on the far side of a bright line, but the tension between the Spacepower Doctrine and the OST makes clear that the treaty’s authority is softening at its edges. The balance of international risk has shifted, though extreme shared risks remain. As in the Cold War, the United States is once again involved in a “great power competition,” in which nations are projecting military might across many spheres. But now, if compared to the 1960s, there is a huge asymmetry in vulnerability, with China’s power growing, and the United States the most sensitive to attack. Experts focused on pursuing peace, or at least safety, in space now see two paths to that end: through further diplomatic efforts and arms control, or through a new assertion of military supremacy. The problem is that there’s a lack of willingness to limit the arsenals in order to achieve better global stability.

Both China and Russia have proposed drafts of a space arms-control treaties which would theoretically ban all types of weapons in space, but they lack of means of verification and their implicit allow direct-ascent ASAT weapons. Further, treaties such as this would put the United States at a disadvantage. The U.N. Committee on the Peaceful Uses of Outer Space, currently focused on establishing guidelines to limit the creation of space debris, says that any new binding treaty in the current geopolitical environment is impossible. But if deterrence fails, a war that begins or extends into space will be fought over great distances at tremendous speeds. Direct-ascent anti-satellite missiles can reach low Earth orbit in minutes. Electronic attacks and directed-energy weapons move at the speed of light, and on-orbit capabilities move at speeds greater than 17,500 mph. To plan for such warfare, we must be lean, agile, and absolutely fast.

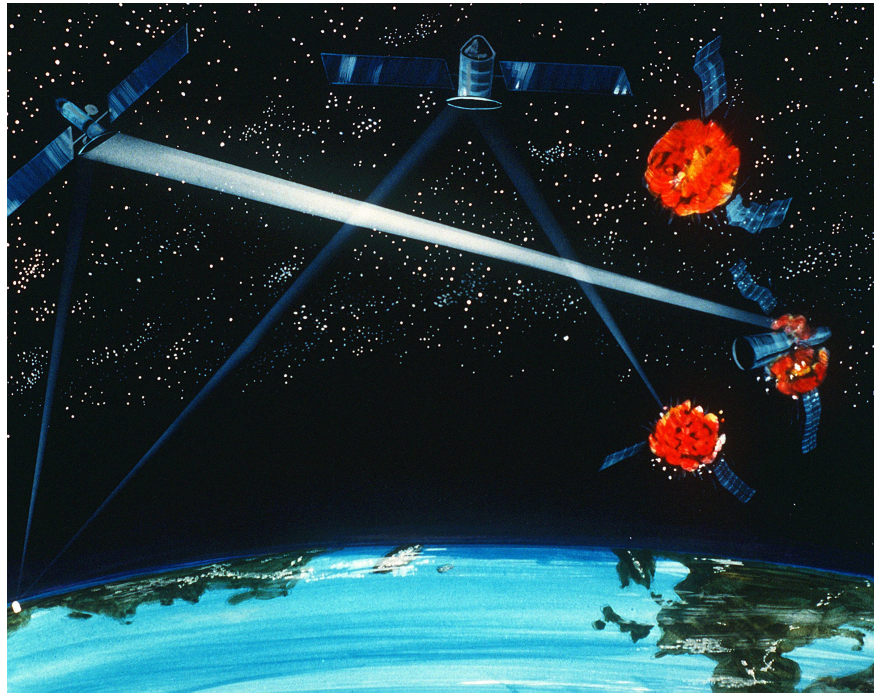

Fig. 7 An artist's concept of a ground and space-based hybrid laser weapon, Strategic Defense Initiative, 1984

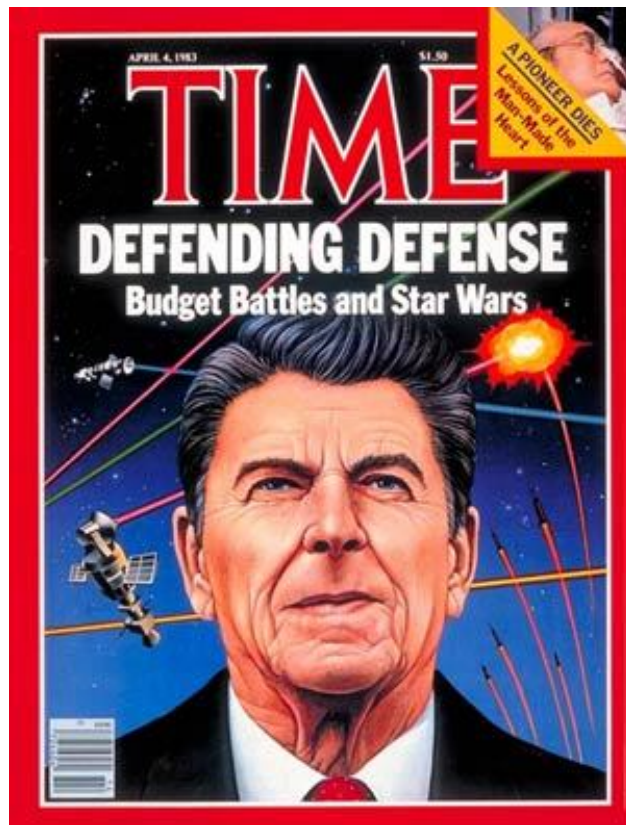

Fig. 8 Defending Defense: Budget Battles and Star Wars. Times, April 4th, 1983.



## II. Transport systems and overall architecture

This framework consists of a plenty of space stations and spacecraft for interplanetary crew and cargo transportation, called *Spectre*. Several facilities on Earth are planned to be built, for the collection, sorting and reconditioning of waste materials, design, construction, testing and launch of new orbital infrastructures, and assistance, management and administration of the Framework. The first *Spectre* spacecrafts and *Redstar* space stations should be built on Earth, but after a couple of years the orbital segment should already be able to replicate itself autonomously.

A *Redstar* space station would be indicated by an abbreviation like RDST-X-Y, with X a number representing the planet by distance from the Sun and Y a letter indicating the order of arrival on that planet. A *Spectre* would be similarly identified by an abbreviation STR-XXY, where XX are the last two digits of the year of registration and Y is a letter indicating the order of registration in that year.

### A. Project Ikarus and the Spectre multipurpose spacecraft

*Spectre* is a multipurpose spacecraft, ultimate goal of *Project Ikarus*, capable of carrying a crew of 8 plus a payload of at least 150 t or 50 people. It is designed to perform long-duration manned or autonomous spaceflights to any destination in the Solar System and to work on large orbital infrastructures, like an *enhanced Space Shuttle*.

A fleet consisting of 6 units is expected: *Ranger, Aquila, Altair, Hydra, Lyra, Lazarus*. The names are inspired by some constellations of the Northern sky and by the names of fictional vehicles. SPECTRE (Special Executive for Counter-intelligence, Terrorism, Revenge and Extortion) is a fictional organisation featured in the James Bond novels by Ian Fleming, as well as the films and video games based on those novels.

The final *Spectre* spacecraft should be made by 9 modules connected by several large corridors; the core module should not be removed since it contains the bridge, the crew quarters, the electrical equipment, the propellant, the air and water tanks, the two parachutes and the fusion reactor (see later). The other modules could be used as cargo holds or passenger bridges. Even if the base of the vehicle is in one piece, the primary superstructure could be removed to perform the appropriate fittings, between cargo configuration and passenger configuration.

The superstructure should be in a composite material based on carbon, with an integrated thermal protection system. The project also has two airlocks, with which it could dock with other spacecraft equipped with the NASA Docking System and allow spacewalks. The power supply for the electrical systems would come from fusion reactor on board or, during flights of shorter duration, from the covering in photovoltaic panels. To land on any surface in the Solar System, it is equipped with retractable landing gears, driven by small asynchronous motors, and a triple vertical parachute.

The on-board systems should be managed by a Unix-like system, which simultaneously perform the same calculations to assume the statistically best values. The autonomous inertial navigation system would consist of an inertial measurement unit, optical groups connected to reference telescopes to stellar and radar for the altimeter data of the take-off and landing phases, in addition to the on-board computers, which should be managed directly by the crew using touch screen displays.

The *Project Ikarus* series of aircrafts saw the light of day in 2019, with the design of Ikarus-X; this had the ultimate goal of testing the feasibility of an hybrid propulsion system in the atmosphere. The second vehicle, Ikarus-Y, served as a theoretical workbench on which develop the aerodynamics and the originally all-electric propulsion system that would have been tested on Ikarus-Z. Starting from a preliminary design, shown in Fig. 10, in which the *Laserfan Mark III* rocket engine was introduced, a third design called Ikarus-Z was created.

Going back to the architecture of Ikarus-X, one could think about a system that switches from an orbital *Solar-Electric Propulsion* based on an air-breathing ion thruster, to a high-altitude conventional airship propelled by a fan. To accomplish this result, Ikarus-Z features an innovative X-shaped design in which the *Skyraker* engines are put between the starboard (S) and port (P) modules. These engines are nothing less than *Laserfan Mark III*s fitted with a pumping system that takes Helium gas into and out the inflatable balloon that covers *Skyraker*. Dedicated tanks on board *Ikaurs-Z* modules will store the Helium gas needed. For moving inside the atmosphere, *Skyraker* acts by simply bypassing the air from the front to the back of the vehicle, passing through the balloon itself. A fourth design, Ikarus-YA, is essentially Ikarus-Y with the *Skyraker* engines designed for Ikarus-Z, instead of the original (unuseful) *Laserfan Mark III*.

In this way, one could get a vehicle capable of reaching altitudes up to 30 km or more, allowing them to penetrate various regions of the atmosphere, including the stratosphere, without the need of rocket propulsion and to sustain such prolonged flight for several days. Moreover, this is the best way to produce a *Spectre* vehicle capable of both space and atmospheric travel with zero emissions, since the propulsion is completely carbon-free.



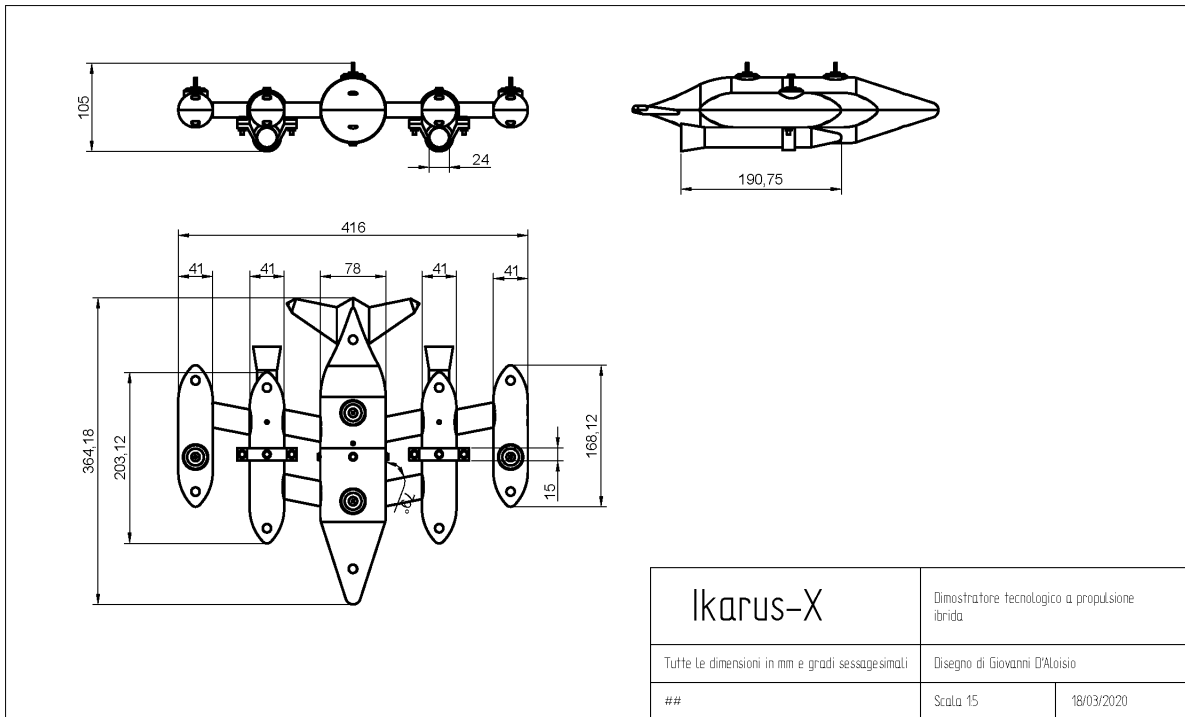

**Fig. 9** Ikarus-X, the first aircraft of the *Project Ikarus* series.

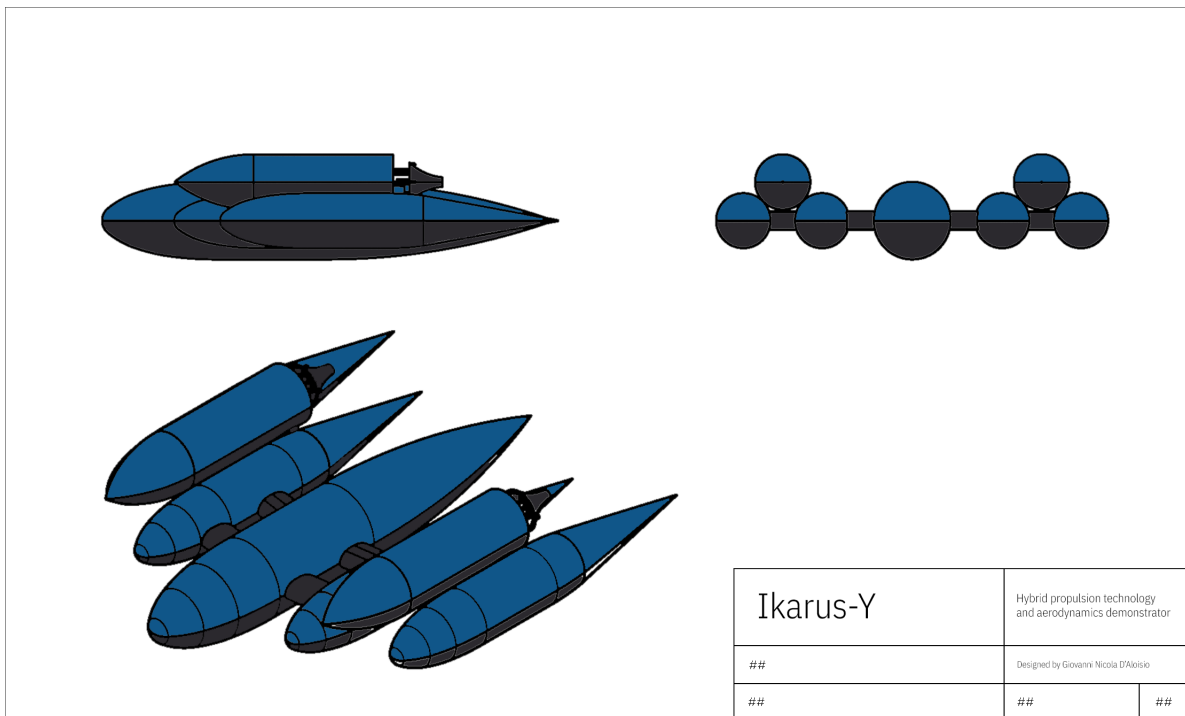

**Fig. 10** Ikarus-Y, the second aircraft of the *Project Ikarus* series. It can be noticed, between the lateral modules of the aircraft, the Skyraker propulsion system.

## B. Project Laserfan and the Skyraker propulsion system

*Skyraker* is a thruster for aerospace applications, and it is the fundamental basis of *Spectre* multipurpose spacecraft.

The original idea envisaged a turbofan derived from the GE LM6000 module, from which the blades in the turbines for the expansion of the exhaust gases were removed, the number of compression stages reduced to a third and the fuel injectors themselves removed, replaced by a uniformly arranged series of compressed hydrogen pellets on the inner crown of the throat section. An electrically operated gate valve could isolate the compression section from the others. At takeoff a three-phase synchronous motor would power the fan, as is the case in a conventional electric aircraft. At 20 km altitude, with supersonic flight regime, the compression section would have been closed and a series of laser beams would have caused the nuclear fusion of the hydrogen pellets. By the principle of action and reaction *Spectre* would have achieved the speed necessary to pass the Earth's atmosphere without the need for any propellant, and all orbital maneuvers would have been performed with ion grid thrusters. Possibly, also the entry maneuvers in trans-planetary orbits would have been made faster by reusing *Skyraker*, since in orbit the throat module would have been replaced to allow up to 5 ignitions, with a refurbishment system similar to that of a conventional magazine pistol.

The final idea, however, foresees that the engine should be designed to drive the *Spectre* spacecraft, solely via some kind of *Solar Electric Propulsion* (SEP), or a X-RAYJAR nuclear reactor. The final project plans to produce thrust from the compression and ionization of atmospheric gases (i.e. air), for electrostatic grids and/or the Hall effect.

Looking at Fig. 11, it should be taken in consideration the fact that all these systems are inside the *Skyraker* itself; any further tank or subsystem should be implemented inside *Spectre*, but only if the flight requirements need it.

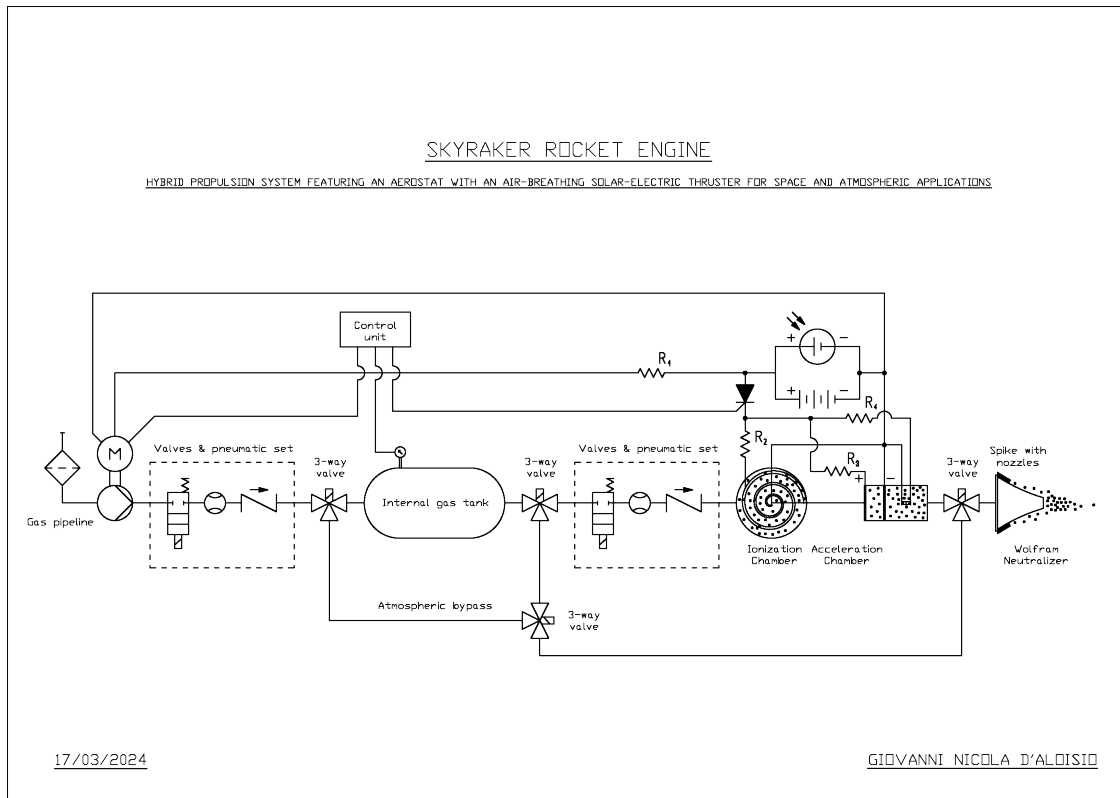

**Fig. 11 Schematic flow diagram of a *Skyraker* rocket engine prototype.**

Design is underway for a model which adopts an entirely different philosophy, based on the magnetic reconnection of plasmoids. For further information, see Ebrahimi, F. (2020) \*.

\*An Alfvénic reconnecting plasmoid thruster. Journal of Plasma Physics, 86(6), 905860614. doi:10.1017/S0022377820001476

### C. Project Kyber and the X-RAYJAR energy system

X-RAYJAR (*X-RAY Junction for Advanced Reactions*) is the reactor designed to power the farthest REDSTAR space stations and the interstellar *Spectre* spacecrafts. It exploits the properties of inertial nuclear fusion to produce electricity.

In a white dwarf, the energy produced by nuclear fusion reactions is no longer able to balance the gravitational force, which would cause the star to collapse; then a completely degenerate Fermi gas is formed, in which the degenerative pressure of the electrons manages to bring the star back to a relatively stable state. The gas is extremely hot but the radiative surface area is very small, so it takes an extremely long time interval for all the energy to radiate out.

By carrying out a nuclear fusion reaction of a light hydrogen compound by inertial confinement inside a sufficiently resistant hermetic vessel, the shock wave returning to the heart of the reaction can lead to the formation of a gas analogous to the one found in the core of a white dwarf, but exponentially smaller. The high temperature reached, combined with the low irradiation surface and the degenerative pressure of the electrons, can therefore be exploited in a thermal cycle, with thermocouples or in other ways to produce electricity. The main problem with this technology is, of course, the maintenance of such an intense energy source inside a sealed container, which is the main reason for developing tokamaks instead of inertially-confined reactors.

The idea of X-RAYJAR Mark I is to exploit the magnetic field produced by the nucleus to induce a voltage which, in turn, can be used to generate an opposite magnetic field, which keeps the source in static equilibrium with the surrounding environment; the external radiating surface, spherical in shape, would have an extremely high albedo, in order to limit the heating by radiation of the external membrane. Appropriately shielded optical fibers would be mounted at the ends of one or more of the diameters, capable of carrying the electromagnetic waves produced by the nucleus towards photovoltaic cells and thus producing electricity.

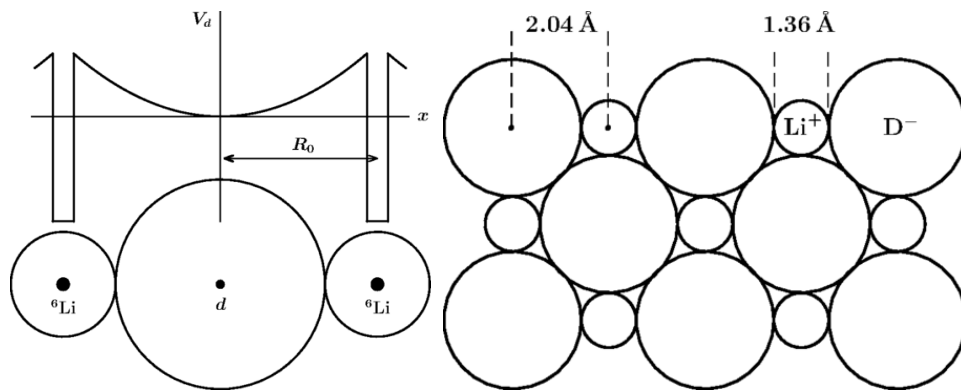
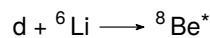

Fig. 12 Potential energy of a Deuteron nucleus with two neighboring Lithium atoms in a LiD crystal.

A design like this is very hard to create; fortunately, this is not the only way to solve the problem.

The nuclei that constitute a crystalline lattice oscillate relative to each other with a very low energy that is not sufficient to penetrate through the Coulomb barriers separating them. An additional energy, which is needed to tunnel through the barrier and fuse, can be supplied by external electromagnetic waves (X-rays or synchrotron radiation). Exposing the solid compound LiD (lithium deuteride) to X-rays for the duration of 111 h, 88 events of nuclear fusion:



are detected. The theoretical estimate agrees with this observation.

One possible application of the phenomenon is in measurements of the rates of various nuclear reactions at extremely low energies inaccessible in accelerator experiments; X-RAYJAR Mark II uses a heavily compressed crystal of lithium deuteride (LiD) doped by ion implantation with protons, deuterium and/or tritium. This crystal is then placed in a chamber, where a series of laser beams irradiate the nuclei of hydrogen, triggering many nuclear fusion reactions whose products,  $\alpha$  and  $\gamma$  rays, are picked up by particular transducers alternating with the lasers on the walls of the chamber. This scenario is supported by a study published by Belyaev et al. on 28 March 2016. The reaction can be sustained depending on the space on board the vehicle hosting the reactor, but X-ray nuclear fusion appears to be a relatively cheap, simple and safe route. Moreover, the fusion products then remain confined in the crystal, which can be removed for renewal, and critical temperatures are not reached, except within the hot-spots.

#### D. Project Konigsberg and the Redstar space stations

REDSTAR (*Research and Exploration Development Station for Space Technology Advancements and Research*) is a multipurpose orbiting infrastructure capable of hosting scientists, engineers and even space tourists. It is made up of three sections, each of which has specific and interconnected structures and functions:

- I.N.N.O.V.A.T.E. (*Innovative Nexus for Navigation, Observation, Verification, and Advanced Technological Exploration*) is made up of four flexible modules, connected to each other through as many nodes/airlocks/docking compartments, forming a square. This section is used as a multipurpose orbiting laboratory, and each module is divided into several floors according to the TransHab<sup>†</sup> model.
- L.U.X.E. (*Living Units for Xenial Exploration*) is made up of four flexible modules connected in the same way that communicate transversely with *Li*. This section is the outpost's guest living area, also in the TransHab style, and it is designed for commercial purposes. It is the only section in which there's no access to the outpost's main control system.
- I.N.F.R.A.S. (*Interplanetary Navigation and Functional Resource Assembly System*) is made up of nine rigid modules, which contain the electrical equipment, the navigation and command systems and the food supplies. A depressurized lattice structure houses the photovoltaic panels, the main antennas, the spare parts, the propellant tanks, the depressurized hangars, four robotic arms and the solar electric propulsion.

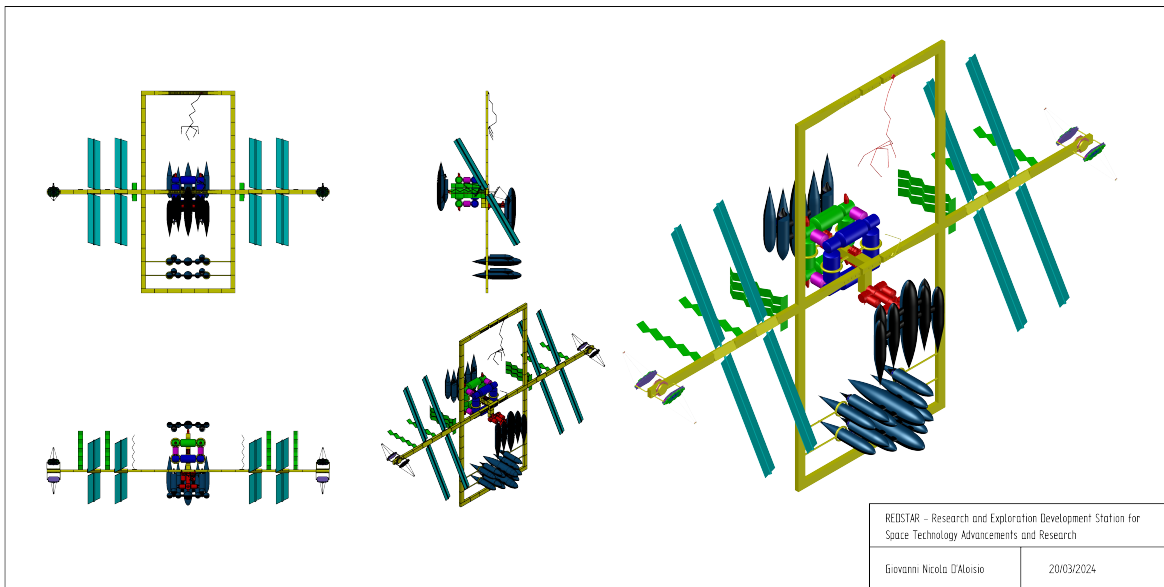

**Fig. 13 Preliminary design of REDSTAR. Notice the INNOVATE and LUXE sections, behind the yellow Integrated Truss Structure, and the INFRAS section, red, in front of it. The huge black and blue vehicles are the Spectre S spacecrafts, docked at the station and at the shipyard. On the sides of the solar panels, there are the main communication antennas and the thermal radiators.**

It is estimated that each pressurized rigid module has a diameter and average internal length of at least 8 and 16 m, for a total of 6400 m<sup>3</sup> of habitable volume, more than 8 times that of the International Space Station. Each *Spectre* in cargo configuration is capable of transporting four modules at a time, consequently a dozen flights are sufficient for its completion. At that point the station would be populated by 50 people plus an emergency *Spectre S*.

A possible assembly sequence could start from the Solar-Electric Propulsion system, with the main antennas, the framing, the propellant tanks and the photovoltaic panels; then, the pressurized sections. Finally, EXPRESS Logistics Carriers, robotic arms and space yard systems.

Once completed, a REDSTAR would be capable of reaching any orbit in the terrestrial and, if equipped with the X-RAYJAR reactor, also other planets of the Solar System, as well as possibly even more distant destinations.

<sup>†</sup>For further information, see AIAA Paper 2000-1822



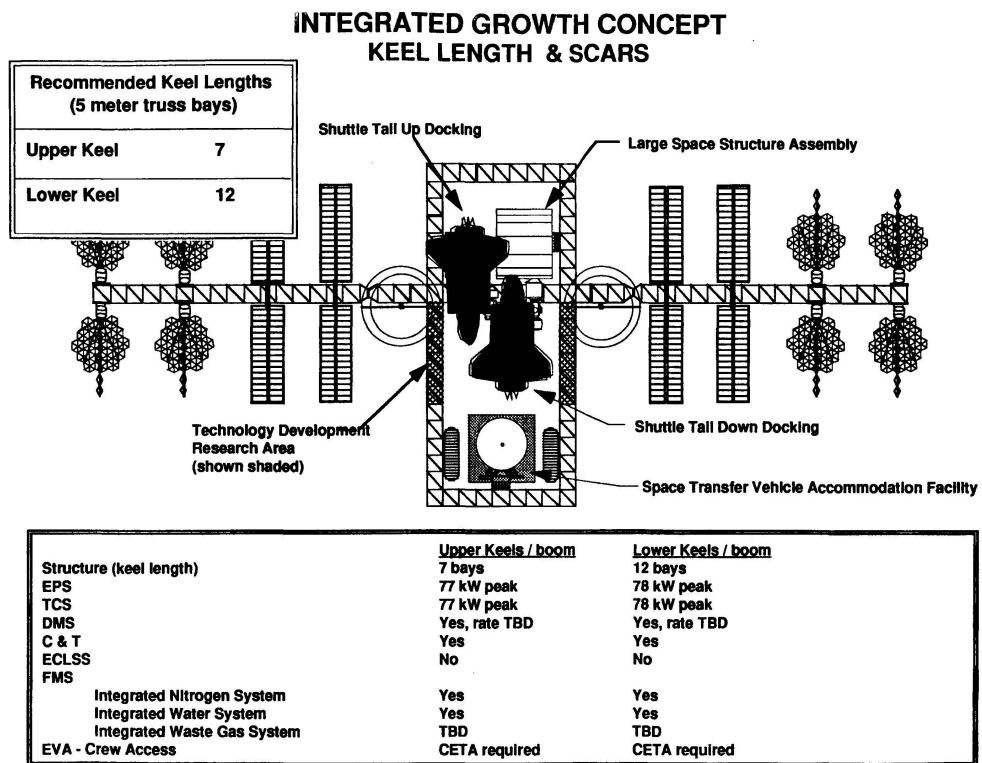

Fig. 14 Diagram from "Space Station Evolution - Beyond the Baseline" (Feb. 6 - 8, 1990, League City, Texas).



Fig. 15 A view of Space Station Freedom, which greatly influenced Redstar.

### III. Perspectives on human evolution enabled by the Space Framework

The *Space Framework* serves as the cornerstone of an entire space economy, providing fertile ground for the emergence of innovative technologies and lifestyles.

Within the Design Reference Architecture 5.0<sup>‡</sup>, objectives for Mars exploration have been outlined, elucidating the challenges of the present century:

- Ability to perform advanced orbital operations in a robotized or supervised manner;
- Definition of new jobs, such as space miners, planetary scientists, space forces, etc.;
- Establishment of interplanetary governmental organizations, for the preservation of Peace in the Solar System;
- Occupation of every body of the Solar System in a way functional to the needs of terrestrial species;
- Definition of new building materials for the construction of new extraterrestrial cities;
- Drafting of a *Space Navigation Code*, of *urban development plans* for preventing the creation of space debris and of international conventions to regulate the relations between the Nations;
- Obtaining full independence of space vehicles and extraterrestrial nations from terrestrial consumables, such as water, food, propellant and spare parts.

The *Space Framework* facilitates international discourse on these and other topics, fostering collaboration on a global scale. Distinguishing itself from ongoing space programs like Artemis and defunct endeavors like Constellation, as well as commercial ventures such as SpaceX and Sea Launch, the European-led *Space Framework* breaks free from dependence on American counterparts. The initiative responds to the prolonged duration of interplanetary missions and the challenging prospect of a manned interstellar mission, which could potentially be realized only in the latter half of the next century, and even then, may span many years.

As the first entirely European-born space framework, it represents a pivotal moment in space exploration. Existing networks, while advanced in terrestrial observation, lack the impetus for robust space exploration. The *Space Framework* aims to address this gap, offering a promising solution to propel humanity's journey beyond Earth's confines.

### IV. Supportability, maintainability and public participation

An ambitious endeavor like the *Space Framework* is contingent upon substantial funding. In 1970, a comparable initiative, the traffic model developed in 1970 as part of the Integrated Program Plan (IPP) in the United States, was projected to require an annual budget of 9 billion 1970 dollars, equivalent to approximately 67 billion in 2022. This model aimed to estimate the maximum flow of space traffic that could be handled by the planned Space Transportation System (also known as the Space Shuttle) under development.

The Integrated Program Plan was a strategic initiative by the United States government aimed at coordinating and planning the development of various space technologies and projects, including the Apollo, Gemini, and Shuttle programs, as well as other space activities. The "Maximum Rate" Traffic Model played a crucial role in assessing the capacity of the planned space transportation system to handle traffic flow and determine its efficiency.

The complexity of such a plan necessitates meticulous consideration of numerous variables, particularly concerning cosmic risks (such as space debris, high-energy particle beams, asteroids, and comets) and human factors. Hence, each study must be conducted meticulously by a cohesive team, ensuring redundancy and ideological alignment.

Estimating the costs of the *Space Framework* poses challenges due to evolving technologies and shifting public opinions since the Sixties. However, experiments conducted over the past century offer invaluable insights into the reliability of adopted technical solutions, enduring over 50 years from deployment. Ion propulsion, for instance, has emerged as the preferred method for prolonged interplanetary missions, offering efficiency and versatility. Nonetheless, further economic analyses are warranted to ascertain the confidence level in these assumptions.

The *Space Framework* involves stakeholders potentially encompassing all UN member states, transcending the interests of scientists and researchers to encompass legal, economic, and individual concerns. It presents an opportunity to foster job creation, alleviate physically demanding occupations, surmount ideological barriers, and galvanize societal development. It offers a paradigm shift in viewing Earth not as the ultimate origin and destination but as the cradle of human exploration and infinite possibilities. Fundamentally, it taps into humanity's innate curiosity and survival instinct, serving as a profound source of inspiration.

Therefore, the financing and participation in the *Space Framework* hold intrinsic value for all stakeholders, with implicit economic returns akin to past space programs.

---

<sup>‡</sup>For further information, refer to NASA-SP-2009-566-Mars-DRA5.

## V. Aftermath

The *Space Framework* presents a remarkably ambitious yet achievable model for a sustainable space economy, catering to a multitude of objectives. Its adaptable architecture lends itself to further refinements, refurbishments, and periodic updates, serving as a foundational platform for enabling human exploration into interstellar space. The envisioned future includes the development of warp drives and other advanced technologies, propelled by the collective efforts of the international scientific community.

To establish a robust and efficient system for space transportation and logistics, beyond foundational space infrastructures, energy generation, and propulsion capabilities, a multitude of supplementary components and services are imperative. Notable examples encompass high-speed satellite communication systems, cutting-edge vital support systems, and radiation shielding technologies. Additionally, the development of infrastructure and services tailored for the maintenance and repair of space shuttles and stations is paramount. This entails integrating autonomous robotic systems and advanced 3D printing technologies for efficient spare part production. Moreover, the implementation of waste management systems for the treatment and disposal of waste is indispensable for ensuring the overall sustainability and functionality of the system.

Robert Goddard, the trailblazing American engineer, professor, physicist, and inventor, famously remarked, “every vision is a joke until the first man accomplishes it; once realized, it becomes commonplace”. Let the *Space Framework* stand as a beacon, embodying humanity’s relentless pursuit of the extraordinary.

## References

- [1] Juan A. Sanchez et al 2021 Planet. Sci. J. 2 205, DOI: 10.3847/PSJ/ac235f.
- [2] Dana G. Andrews et al., *Defining a successful commercial asteroid mining program*, Acta Astronautica 108 (2015) 106-118, DOI: 10.1016/j.actaastro.2014.10.034.
- [3] Shane D. Ross, *Near-Earth Asteroid Mining*, Control and Dynamical Systems, Caltech 107-81, Pasadena, CA 91125, shane@cds.caltech.edu, December 14, 2001, Space Industry Report.
- [4] Rachel Riederer, *Ad Astra*, URL: <https://harpers.org/archive/2021/11/ad-astra-the-coming-battle-over-space/>. Report retrieved in November 2021.
- [5] Wernher von Braun, *Manned Mars Landing Presentation To The Space Task Group*, 4 agosto 1969.
- [6] Stanley K. Borowski, Stephen W. Ryan, David R. McCurdy, Bob G. Sauls, *Commercial and Human Settlement of the Moon and Cislunar Space - A Look Ahead at the Possibilities Over the Next 50 Years*, August 19, 2019.
- [7] Stuart L. Shapiro, Saul A. Teukolsky, *Black Holes, White Dwarfs, and Neutron Stars: The Physics of Compact Objects*.
- [8] R. G. Jahn, *Physics of Electric Propulsion*, McGraw-Hill, 2006.
- [9] V. B. Belyaev, M. B. Miller, J. Otto, and S. A. Rakityansky, *Nuclear fusion induced by x rays in a crystal*, Phys. Rev. C 93, 034622. Published 28 March 2016, DOI: <https://doi.org/10.1103/PhysRevC.93.034622>.
- [10] Terry Kammash, *Fusion Energy in Space Propulsion*, 978-1-56347-184-1, January 1, 1995.
- [11] *Space Station Freedom: A Foothold On The Future*, NASA-NP-107/10-88, 48 pages, 1990.
- [12] *Space Shuttle System Summary*, Rockwell International Space Division, SSV73-45(R), July 1973.
- [13] *Integrated Program Plan "Maximum Rate" Traffic Model (1970)*, URL: <https://www.wired.com/2012/04/integrated-program-plan-maximum-rate-traffic-model-1970/>.
- [14] Barry D. Meredith, P. R. Ahlf, Rudy J. Saucillo, “Space Station Freedom Integrated Research and Development Growth,” in *Beyond the Baseline: Proceedings of the Space Station Evolution Symposium*, vol. 1, pt. 1, pp. Space Station Freedom, Johnson Space Center, NASA Langley Research Center Hampton, VA, United States, May 1990 [Document ID: 20030063196].